



ADDIE'S PLACE

AT BLUEWATER BAY



FRONT ELEVATION C



MORGAN

Options: Fireplace, Master Bath & Pantry Upgrades, & More

2 STORY | 3 BEDROOMS | 3.5 BATHS | 2,721-2,874 SQ FT

FIRST FLOOR
ELEVATION A

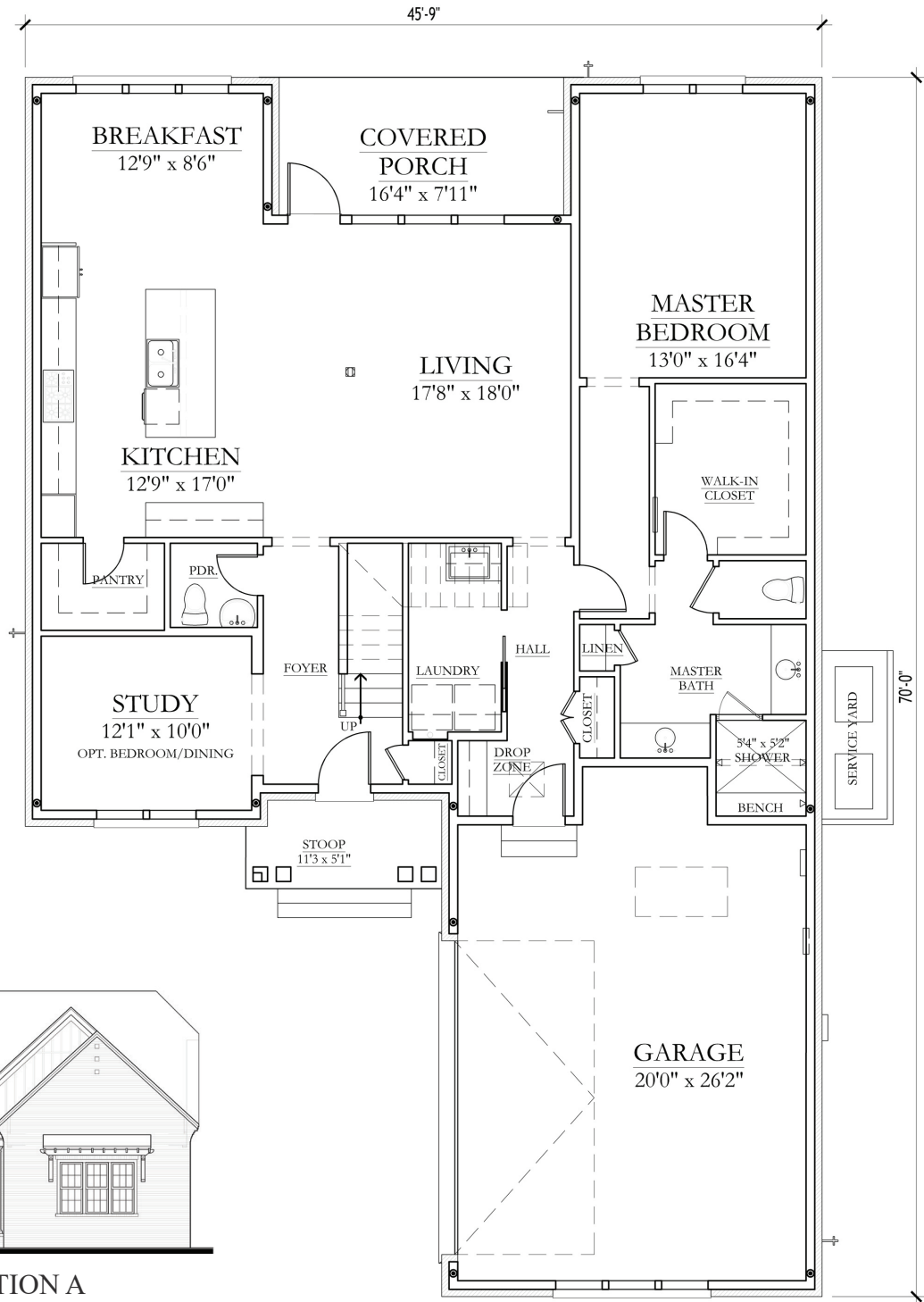

ELEVATION A



ELEVATION B

MORGAN

3 BEDROOMS | 3.5 BATHS

2,721-2,874 SQUARE FEET

TWO STORY

WIDTH OF BUILDING (BRICK) 45'-9"

DEPTH OF BUILDING (BRICK) 70'-0"

*Not shown to scale. Elevation A is standard. Elevations B and C are upgrades.



REAR ELEVATION W/LOFT
EXTENSION - ADD 153 SQ FT

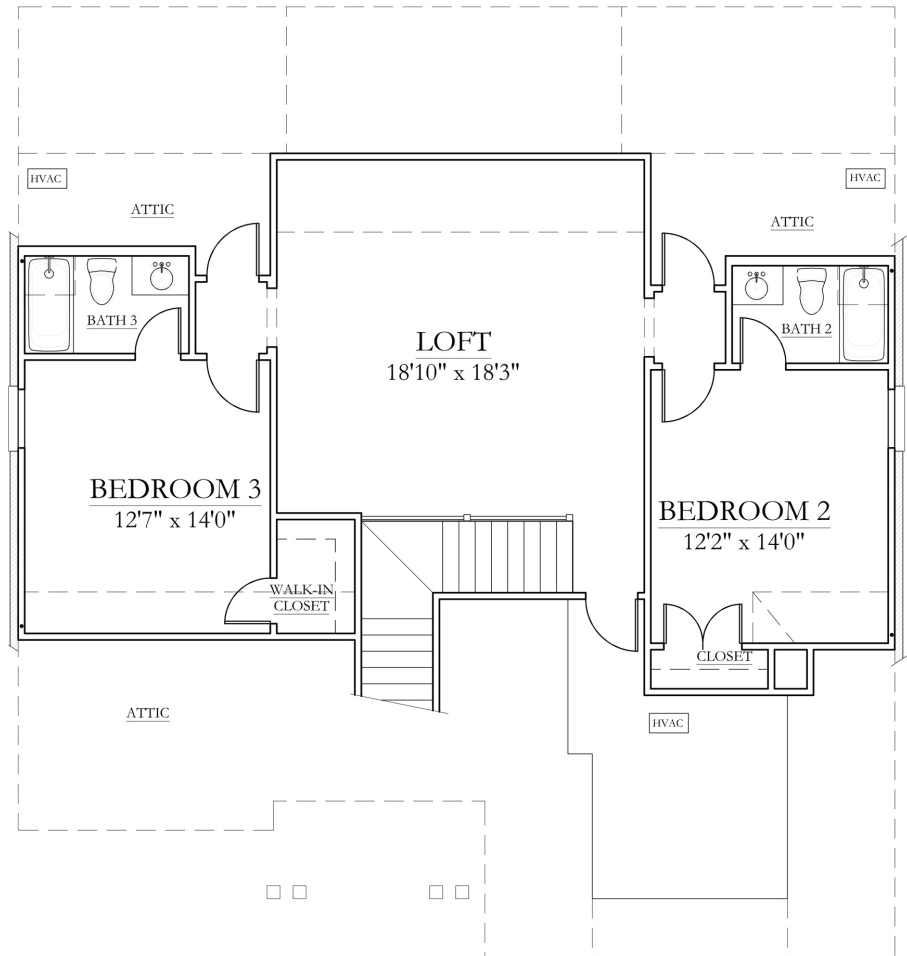

SECOND FLOOR A

* Elevation A is standard. Elevations B & C are upgrades.

This incredible home boasts a substantial open living area for gatherings, celebrations, and spending time with friends and family. Its large kitchen is outfitted with an island, pantry, plentiful counter space, and maximized storage options. Your designated dining space (with outdoor views!) rests comfortably next to the covered porch, where you can spend hours enjoying your tranquil surroundings, hosting cookouts, or lounging in a hammock. For those who work from home—or who have kids that need quiet space for homework—the study is a perfect location for focus. The first-floor master bedroom is an ideal retreat with its considerable size, stunning en-suite, and walk-in closet. Head upstairs to find two additional bedrooms, each with its own en-suite bathrooms, separated by a loft space that can be used as a media room, game room, office, or whatever best fits your lifestyle. The Morgan Plan is waiting to embrace your family!



ADDIE'S PLACE
AT BLUEWATER BAY

MORGAN OPTIONS

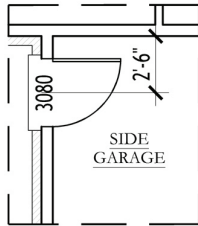

MAN-DOOR
AT SIDE GARAGE

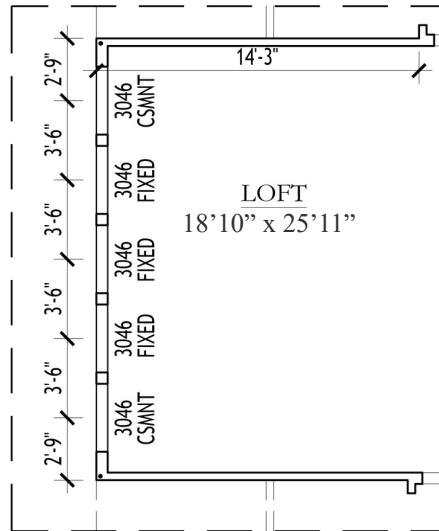

LOFT EXTENSION
ADD 153 SQ FT

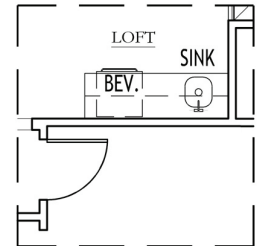

WETBAR

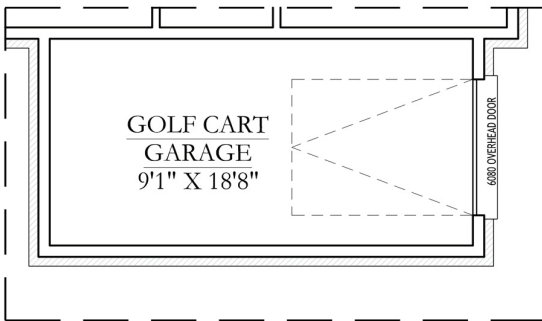

GOLF CART GARAGE
ADD 171 SQ FT

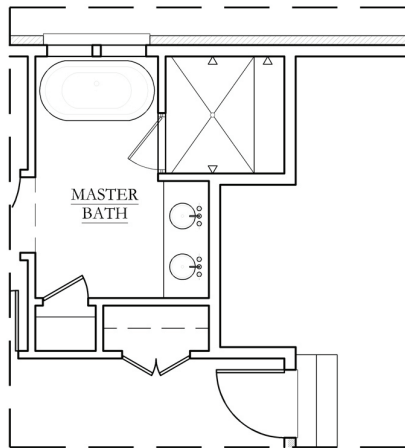

MASTER BATH

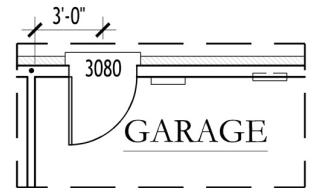

MAN-DOOR

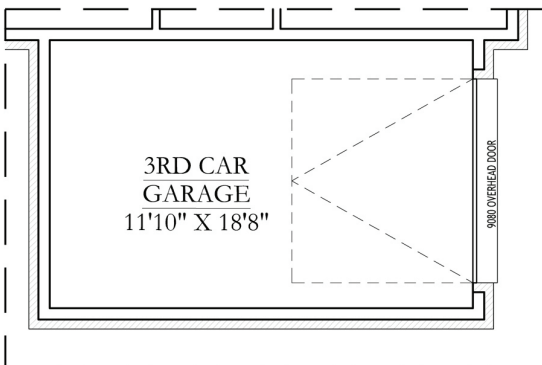

3RD CAR GARAGE
ADD 256 SQ FT

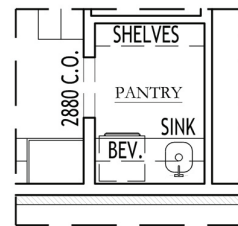

PANTRY

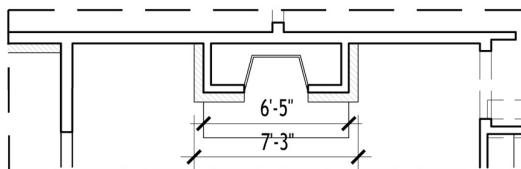

FIREPLACE



RandyWiseHomes.com | 127 N Partin Drive | Niceville, FL 32578 | RG 0029913



©Copyright – Randy Wise Homes, Inc. 2022. Elevation, floorplans, prices, specifications and amenities are subject to change without notice. House plan drawings and any associated specifications and option lists are the property of Randy Wise Homes, Inc. Reproduction of these documents either in whole or in part, including any form of copying and/or preparation of derivative works thereof, for any reason, is strictly prohibited.

